

Name: _____

CIS 351 Sample P2 Problem

31 March 2022

P2: Data Hazards

(a) Identify the 5 data hazards in the following code fragment. For each hazard, state whether it can be solved by forwarding or if stalls are necessary. Assume branches are resolved in the decode step.

```
1. addi $v0, $zero, 0
2. sll  $a1, $a1, 2
3. add  $t1, $a0, $a1
4. lw   $t2, 0($t1)
5. add  $v0, $v0, $t2
6. addi $t1, $t1, 4
7. slt  $t3, $v0, $zero
```

(b) Draw a pipeline diagram showing the execution of the code above on a 5-stage pipeline with no data or register forwarding.

(c) Highlight the forwarding path used by `$t1` between the first and second instruction below.

```
addi $t1, $zero, 15
add  $t5, $t1, $t7
```

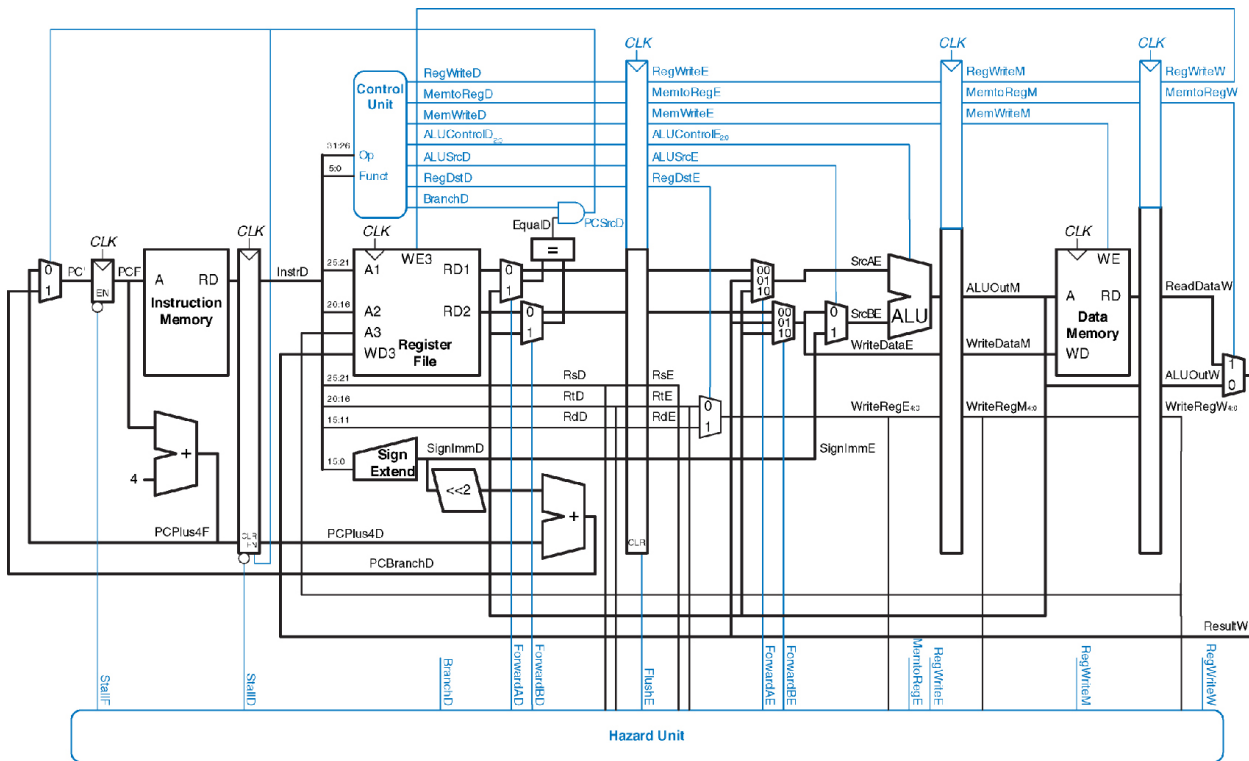

© 2007 Elsevier, Inc. All rights reserved

- (d) Explain how the use of branch delay slots allows the pipelined processor to “handle” control hazards without adding extra hardware. If the hardware isn’t “handling” the hazard, what is?
- (e) Draw a pipeline diagram showing the execution of the code below on a 5-stage pipeline that has data forwarding, but handles control hazards by stalling.

```

addi $t0, $zero, 15
addi $t1, $zero, 15
beq $t0, $t1, target
sub $t1, $t2, $t3
add $t4, $t5, $t6
lw $t7, 0($a0)
target: add $v0, $zero, 100
    
```

(solution)